

LM74 SPI/Microwire12-Bit Plus Sign Temperature Sensor

Check for Samples: [LM74](#)

FEATURES

- **0.0625°C Temperature Resolution**
- **Shutdown Mode Conserves Power Between Temperature Reading**
- **SPI and MICROWIRE Bus Interface**
- **5-Bump DSBGA Package Saves Space**

APPLICATIONS

- **System Thermal Management**
- **Personal Computers**
- **Disk Drives**
- **Office Electronics**
- **Electronic Test Equipment**

KEY SPECIFICATIONS

- **Supply Voltage 3.0V or 2.65V to 5.5V**
- **Supply Current**
 - **Operating**
 - **265µA (typ)**
 - **520µA (max)**
 - **Shutdown**
 - **3µA (typ)**
- **Temperature Accuracy**
 - **-10°C to 65°C, ±1.25°C(max)**
 - **-25°C to 110°C, ±2.1°C(max)**
 - **-55°C to 125°C, ±3°C(max)**

DESCRIPTION

The LM74 is a temperature sensor, Delta-Sigma analog-to-digital converter with an SPI and MICROWIRE compatible interface. The host can query the LM74 at any time to read temperature. A shutdown mode decreases power consumption to less than 10 µA. This mode is useful in systems where low average power consumption is critical.

The LM74 has 12-bit plus sign temperature resolution (0.0625°C per LSB) while operating over a temperature range of -55°C to +150°C.

The LM74's 3.0V to 5.5V supply voltage range, low supply current and simple SPI interface make it ideal for a wide range of applications. These include thermal management and protection applications in hard disk drives, printers, electronic test equipment, and office electronics. The LM74 is available in the SOIC package as well as the 5-Bump DSBGA package.

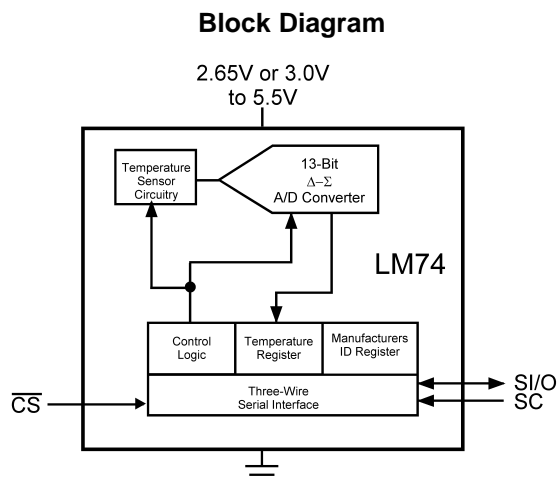

Figure 1.



Please be aware that an important notice concerning availability, standard warranty, and use in critical applications of Texas Instruments semiconductor products and disclaimers thereto appears at the end of this data sheet.

All trademarks are the property of their respective owners.

Connection Diagram

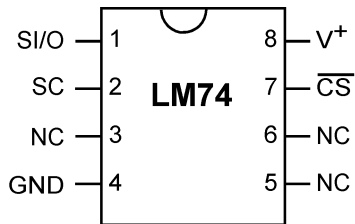

Figure 2. SOIC – Top View
See Package Number D

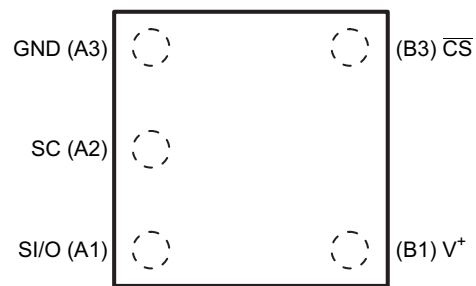

Figure 3. 5-Bump DSBGA – Top View
See Package Number YTA0005

PIN DESCRIPTIONS

Label	SOIC Pin #	DSBGA Pin #	Function	Typical Connection
SI/O	1	1	Slave Input/Output - Serial bus bi-directional data line. Schmitt trigger input.	From and to Controller
SC	2	5	Slave Clock - Serial bus clock Schmitt trigger input line.	From Controller
NC	3		No Connection	No Connection
GND	4	4	Power Supply Ground	Ground
NC	5		No Connection	No Connection
NC	6		No Connection	No Connection
\overline{CS}	7	3	Chip Select input.	From Controller
V ⁺	8	2	Positive Supply Voltage Input	DC Voltage from 3.0V to 5.5V for the LM74CIM and 2.65V to 5.5V for the LM74CIBP and LM74CITP. Bypass with a 0.1 μ F ceramic capacitor.

Typical Application

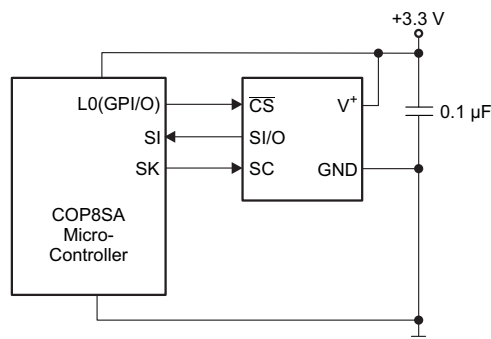

Figure 4. COP Microcontroller Interface



These devices have limited built-in ESD protection. The leads should be shorted together or the device placed in conductive foam during storage or handling to prevent electrostatic damage to the MOS gates.

Absolute Maximum Ratings⁽¹⁾

Supply Voltage	-0.3V to 6.0V
Voltage at any Pin	-0.3V to V^+ + 0.3V
Input Current at any Pin ⁽²⁾	5 mA
Package Input Current ⁽²⁾	20 mA
Storage Temperature	-65°C to +150°C
ESD Susceptibility ⁽³⁾	
Human Body Model	
LM74CIBP and LM74CITP, pin A2 (SC)	1900V
LM74CIM, LM74CIBP, and LM74CITP all other pins	2000V
Machine Model	200V
<i>Soldering process must comply with Reflow Temperature Profile specifications. See www.ti.com/packaging.⁽⁴⁾</i>	

- (1) Absolute Maximum Ratings indicate limits beyond which damage to the device may occur. DC and AC electrical specifications do not apply when operating the device beyond its rated operating conditions.
- (2) When the input voltage (V_I) at any pin exceeds the power supplies ($V_I < \text{GND}$ or $V_I > +V_S$) the current at that pin should be limited to 5 mA. The 20 mA maximum package input current rating limits the number of pins that can safely exceed the power supplies with an input current of 5 mA to four.
- (3) Human body model, 100 pF discharged through a 1.5 k Ω resistor. Machine model, 200 pF discharged directly into each pin.
- (4) Reflow temperature profiles are different for lead-free and non-lead-free packages.

Operating Ratings

Specified Temperature Range	T_{MIN} to T_{MAX}
See ⁽¹⁾	
LM74CIBP and LM74CITP	-40°C to +125°C
LM74CIM	-55°C to +150°C
Supply Voltage Range (+ V_S)	
LM74CIBP and LM74CITP	+2.65V to +5.5V
LM74CIM	+3.0V to +5.5V

- (1) The life expectancy of the LM74 will be reduced when operating at elevated temperatures. LM74 θ_{JA} (thermal resistance, junction-to-ambient) when attached to a printed circuit board with 2 oz. foil is summarized as: Device Number LM74CIM Thermal Resistance (θ_{JA}) 160°C/W. Device Number LM74CIBP Thermal Resistance (θ_{JA}) 250°C/W. Device Number LM74CITP Thermal Resistance (θ_{JA}) 250°C/W.

Temperature-to-Digital Converter Characteristics

Unless otherwise noted, these specifications apply for $V^+ = 2.65\text{V}$ to 3.6V for the LM74CIBP -3, LM74CITP-3, $V^+ = 3.0\text{V}$ to 3.6V for the LM74CIM -3 and $V^+ = 4.5\text{V}$ to 5.5V for the LM74 -5⁽¹⁾. **Boldface limits apply for $T_A = T_J = T_{\text{MIN}}$ to T_{MAX}** ; all other limits $T_A = T_J = +25^\circ\text{C}$, unless otherwise noted.

Parameter		Conditions	Typical ⁽²⁾	LM74-5 Limits ⁽³⁾	LM74-3 Limits ⁽³⁾	Units (Limit)
Temperature Error ⁽¹⁾		$T_A = -10^\circ\text{C}$ to $+65^\circ\text{C}$		± 1.25	± 1.25	$^\circ\text{C}$ (max)
		$T_A = -25^\circ\text{C}$ to $+110^\circ\text{C}$		± 2.1	$+2.65/-2.15$	$^\circ\text{C}$ (max)
		$T_A = -40^\circ\text{C}$ to $+85^\circ\text{C}$		$+2.65/-1.65$	± 2.15	$^\circ\text{C}$ (max)
		$T_A = -40^\circ\text{C}$ to $+110^\circ\text{C}$		$+2.65/-2.0$	$+2.65/-2.15$	$^\circ\text{C}$ (max)
		$T_A = -55^\circ\text{C}$ to $+125^\circ\text{C}$		± 3.0	± 3.5	$^\circ\text{C}$ (max)
		$T_A = -55^\circ\text{C}$ to $+150^\circ\text{C}$		± 5.0	± 5.0	$^\circ\text{C}$ (max)
Resolution			13			Bits
Temperature Conversion Time	SOIC	See ⁽⁴⁾	280	425	425	ms (max)
	DSBGA	See ⁽⁴⁾	611	925	925	ms (max)
Quiescent Current	SOIC	Serial Bus Inactive	310	520	520	μA (max)
	DSBGA		265	470	470	μA (max)
	SOIC	Serial Bus Active	310			μA
	DSBGA		310			μA
	SOIC	Shutdown Mode, $V^+ = 3.3\text{V}$	7			μA
	DSBGA		3			μA
	SOIC	Shutdown Mode, $V^+ = 5\text{V}$	8			μA
	DSBGA		4			μA

- (1) All SOP (LM74CIM) parts will function over the V^+ supply voltage range of 3V to 5.5V . All DSBGA (LM74SIBP and LM75CITP) parts will function over the V^+ supply voltage range of 2.65V to 5.5V . The SOP (LM74CIM) parts are tested and specified for rated temperature error at their nominal supply voltage for temperature ranges of -10°C to $+65^\circ\text{C}$, -55°C to $+125^\circ\text{C}$ and -55°C to $+150^\circ\text{C}$. For the SOP (LM74CIM) parts, the temperature error specifications for temperature ranges of -40°C to $+85^\circ\text{C}$, -25°C to $+110^\circ\text{C}$, and -40°C to $+110^\circ\text{C}$ include error induced by power supply variation of $\pm 5\%$ from the nominal value. For the LM74CIM (SOP) parts, the temperature error will increase by $\pm 0.3^\circ\text{C}$ for a power supply voltage (V^+) variation of $\pm 10\%$ from the nominal value. For the LM74CIBP-3 and LM74CITP-3 (DSBGA) parts all accuracies are ensured over the supply range of 2.65V to 3.6V , except for the temperature ranges of -55°C to 125°C and -55°C to $+150^\circ\text{C}$ where the accuracy applies for the nominal supply voltage of 3.3V . For the LM74CIBP-5 and LM74CITP-5 (DSBGA) parts all accuracies are guaranteed over the supply range of 4.75V to 5.25V , except for the temperature ranges of -55°C to 125°C and -55°C to $+150^\circ\text{C}$ where the accuracy applies for the nominal supply voltage of 5.0V . For the LM74CIBP and LM74CITP over -55°C to 125°C and -55°C to $+150^\circ\text{C}$, a power supply variation of $\pm 10\%$ will degrade the accuracy by $\pm 0.3^\circ\text{C}$.
- (2) Typicals are at $T_A = 25^\circ\text{C}$ and represent most likely parametric norm.
- (3) Limits are specified to AOQL (Average Outgoing Quality Level).
- (4) This specification is provided only to indicate how often temperature data is updated. The LM74 can be read at any time without regard to conversion state (and will yield last conversion result). A conversion in progress will not be interrupted. The output shift register will be updated at the completion of the read and a new conversion restarted.

Logic Electrical Characteristics

DIGITAL DC CHARACTERISTICS

Unless otherwise noted, these specifications apply for $V^+ = 2.65\text{V}$ to 3.6V for the LM74CIBP -3, LM74CITP-3, $V^+ = 3.0\text{V}$ to 3.6V for the LM74CIM -3 and $V^+ = 4.5\text{V}$ to 5.5V for the LM74 -5⁽¹⁾. **Boldface limits apply for $T_A = T_J = T_{MIN}$ to T_{MAX}** ; all other limits $T_A = T_J = +25^\circ\text{C}$, unless otherwise noted.

Symbol	Parameter	Conditions	Typical ⁽²⁾	Limits ⁽³⁾	Units (Limit)
$V_{IN(1)}$	Logical "1" Input Voltage			$V^+ \times 0.7$	V (min)
				$V^+ + 0.3$	V (max)
$V_{IN(0)}$	Logical "0" Input Voltage			-0.3	V (min)
				$V^+ \times 0.3$	V (max)
	Input Hysteresis Voltage	$V^+ = 3.0\text{V}$ to 3.6V	0.8	0.35	V (min)
		$V^+ = 4.5\text{V}$ to 5.5V	0.8	0.33	V (min)
$I_{IN(1)}$	Logical "1" Input Current	$V_{IN} = V^+$	0.005	3.0	μA (max)
$I_{IN(0)}$	Logical "0" Input Current	$V_{IN} = 0\text{V}$	-0.005	-3.0	μA (min)
C_{IN}	All Digital Inputs		20		pF
V_{OH}	High Level Output Voltage	$I_{OH} = -400\ \mu\text{A}$		2.4	V (min)
V_{OL}	Low Level Output Voltage	$I_{OL} = +2\ \text{mA}$		0.4	V (max)
$I_{O_TRI-STATE}$	TRI-STATE Output Leakage Current	$V_O = \text{GND}$ $V_O = V^+$		-1	μA (min)
				+1	μA (max)

- (1) All SOP (LM74CIM) parts will function over the V^+ supply voltage range of 3V to 5.5V. All DSBGA (LM74SIBP and LM75CITP) parts will function over the V^+ supply voltage range of 2.65V to 5.5V. The SOP (LM74CIM) parts are tested and specified for rated temperature error at their nominal supply voltage for temperature ranges of -10°C to $+65^\circ\text{C}$, -55°C to $+125^\circ\text{C}$ and -55°C to $+150^\circ\text{C}$. For the SOP (LM74CIM) parts, the temperature error specifications for temperature ranges of -40°C to $+85^\circ\text{C}$, -25°C to $+110^\circ\text{C}$, and -40°C to $+110^\circ\text{C}$ include error induced by power supply variation of $\pm 5\%$ from the nominal value. For the LM74CIM (SOP) parts, the temperature error will increase by $\pm 0.3^\circ\text{C}$ for a power supply voltage (V^+) variation of $\pm 10\%$ from the nominal value. For the LM74CIBP-3 and LM74CITP-3 (DSBGA) parts all accuracies are ensured over the supply range of 2.65V to 3.6V, except for the temperature ranges of -55°C to 125°C and -55°C to $+150^\circ\text{C}$ where the accuracy applies for the nominal supply voltage of 3.3V. For the LM74CIBP-5 and LM74CITP-5 (DSBGA) parts all accuracies are guaranteed over the supply range of 4.75V to 5.25V, except for the temperature ranges of -55°C to 125°C and -55°C to $+150^\circ\text{C}$ where the accuracy applies for the nominal supply voltage of 5.0V. For the LM74CIBP and LM74CITP over -55°C to 125°C and -55°C to $+150^\circ\text{C}$, a power supply variation of $\pm 10\%$ will degrade the accuracy by $\pm 0.3^\circ\text{C}$.
- (2) Typicals are at $T_A = 25^\circ\text{C}$ and represent most likely parametric norm.
- (3) Limits are specified to AOQL (Average Outgoing Quality Level).

SERIAL BUS DIGITAL SWITCHING CHARACTERISTICS

Unless otherwise noted, these specifications apply for $V^+ = 2.65\text{V}$ to 3.6V for the LM74CIBP -3, LM74CITP-3, $V^+ = 3.0\text{V}$ to 3.6V for the LM74CIM -3 and $V^+ = 4.5\text{V}$ to 5.5V for the LM74 -5⁽¹⁾; C_L (load capacitance) on output lines = 100 pF unless otherwise specified. **Boldface limits apply for $T_A = T_J = T_{\text{MIN}}$ to T_{MAX}** ; all other limits $T_A = T_J = +25^\circ\text{C}$, unless otherwise noted.

Symbol	Parameter	Conditions	Typical ⁽²⁾	Limits ⁽³⁾	Units (Limit)
t_1	SC (Clock) Period			0.16 DC	μs (min) (max)
t_2	$\overline{\text{CS}}$ Low to SC (Clock) High Set-Up Time			100	ns (min)
t_3	$\overline{\text{CS}}$ Low to Data Out (SO) Delay			70	ns (max)
t_4	SC (Clock) Low to Data Out (SO) Delay			100	ns (max)
t_5	$\overline{\text{CS}}$ High to Data Out (SO) TRI-STATE			200	ns (max)
t_6	SC (Clock) High to Data In (SI) Hold Time			50	ns (min)
t_7	Data In (SI) Set-Up Time to SC (Clock) High			30	ns (min)

- (1) All SOP (LM74CIM) parts will function over the V^+ supply voltage range of 3V to 5.5V . All DSBGA (LM74SIBP and LM75CITP) parts will function over the V^+ supply voltage range of 2.65V to 5.5V . The SOP (LM74CIM) parts are tested and specified for rated temperature error at their nominal supply voltage for temperature ranges of -10°C to $+65^\circ\text{C}$, -55°C to $+125^\circ\text{C}$ and -55°C to $+150^\circ\text{C}$. For the SOP (LM74CIM) parts, the temperature error specifications for temperature ranges of -40°C to $+85^\circ\text{C}$, -25°C to $+110^\circ\text{C}$, and -40°C to $+110^\circ\text{C}$ include error induced by power supply variation of $\pm 5\%$ from the nominal value. For the LM74CIM (SOP) parts, the temperature error will increase by $\pm 0.3^\circ\text{C}$ for a power supply voltage (V^+) variation of $\pm 10\%$ from the nominal value. For the LM74CIBP-3 and LM74CITP-3 (DSBGA) parts all accuracies are ensured over the supply range of 2.65V to 3.6V , except for the temperature ranges of -55°C to 125°C and -55°C to $+150^\circ\text{C}$ where the accuracy applies for the nominal supply voltage of 3.3V . For the LM74CIBP-5 and LM74CITP-5 (DSBGA) parts all accuracies are guaranteed over the supply range of 4.75V to 5.25V , except for the temperature ranges of -55°C to 125°C and -55°C to $+150^\circ\text{C}$ where the accuracy applies for the nominal supply voltage of 5.0V . For the LM74CIBP and LM74CITP over -55°C to 125°C and -55°C to $+150^\circ\text{C}$, a power supply variation of $\pm 10\%$ will degrade the accuracy by $\pm 0.3^\circ\text{C}$.
- (2) Typicals are at $T_A = 25^\circ\text{C}$ and represent most likely parametric norm.
- (3) Limits are specified to AOQL (Average Outgoing Quality Level).

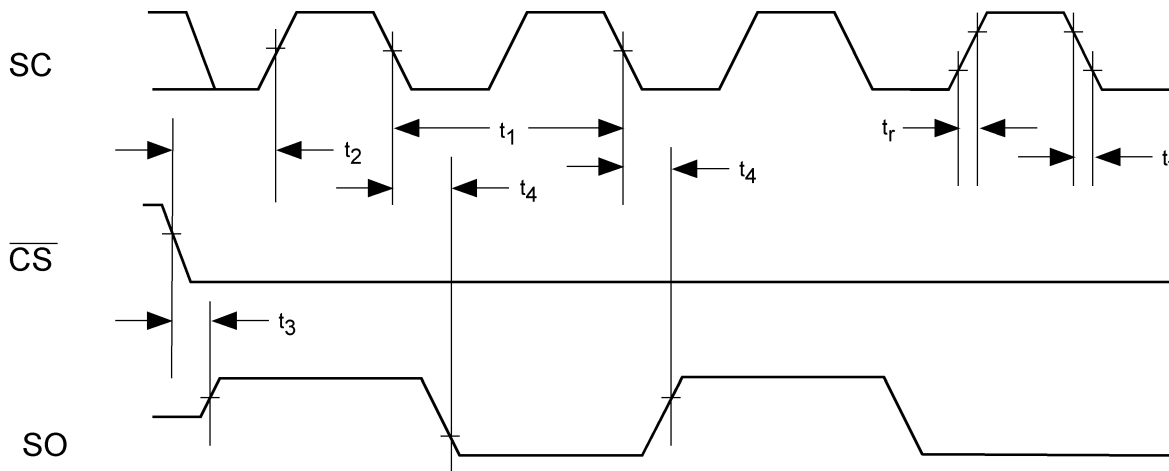

Figure 5. Data Output Timing Diagram

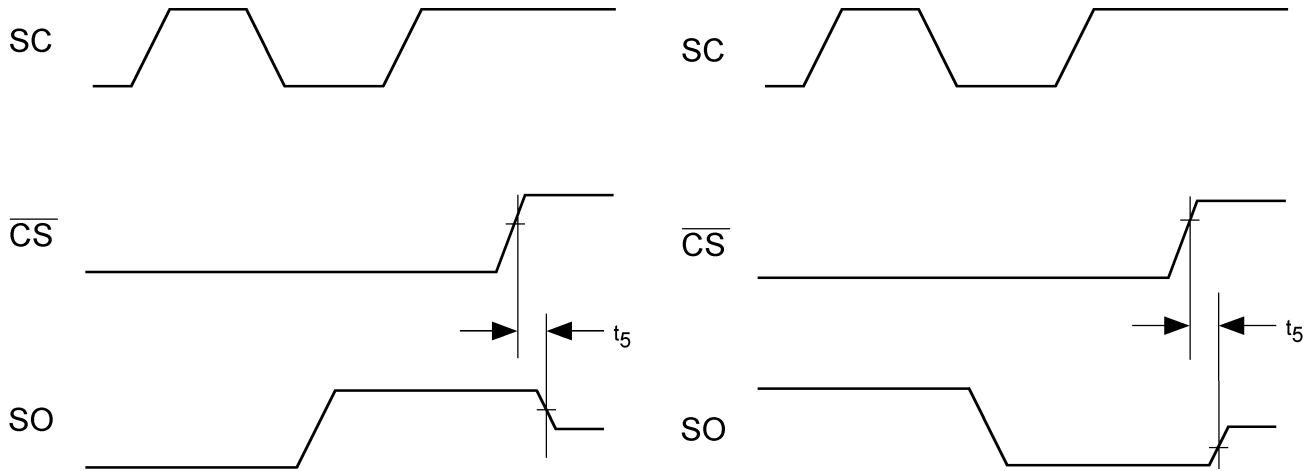

Figure 6. TRI-STATE Data Output Timing Diagram

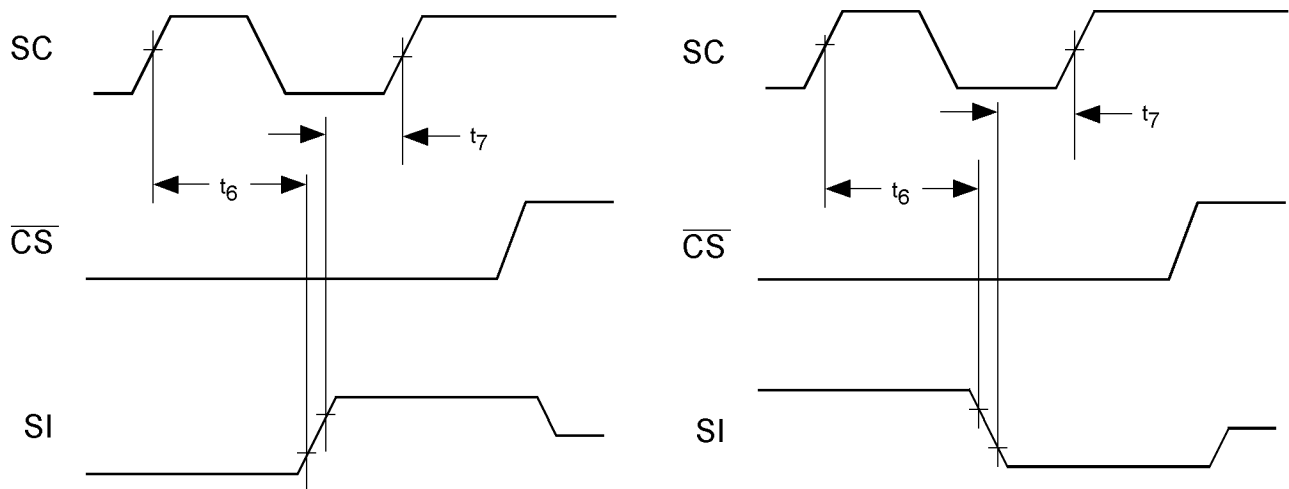

Figure 7. Data Input Timing Diagram

Electrical Characteristics

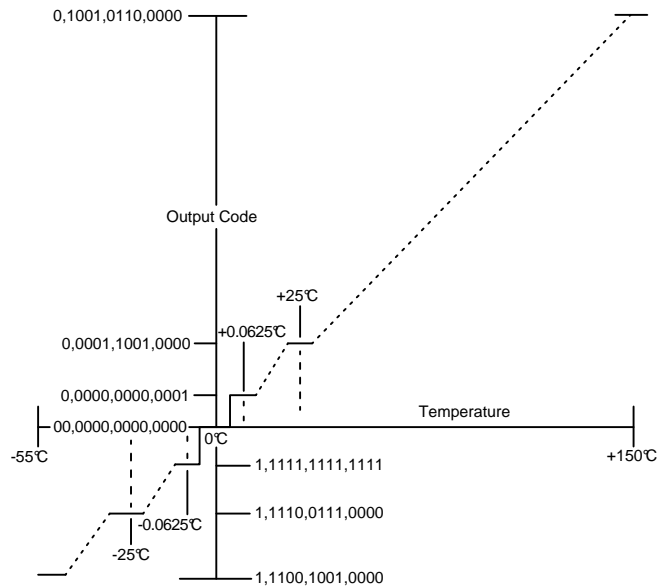

Figure 8. Temperature-to-Digital Transfer Function (Non-linear scale for clarity)

TRI-STATE Test Circuit

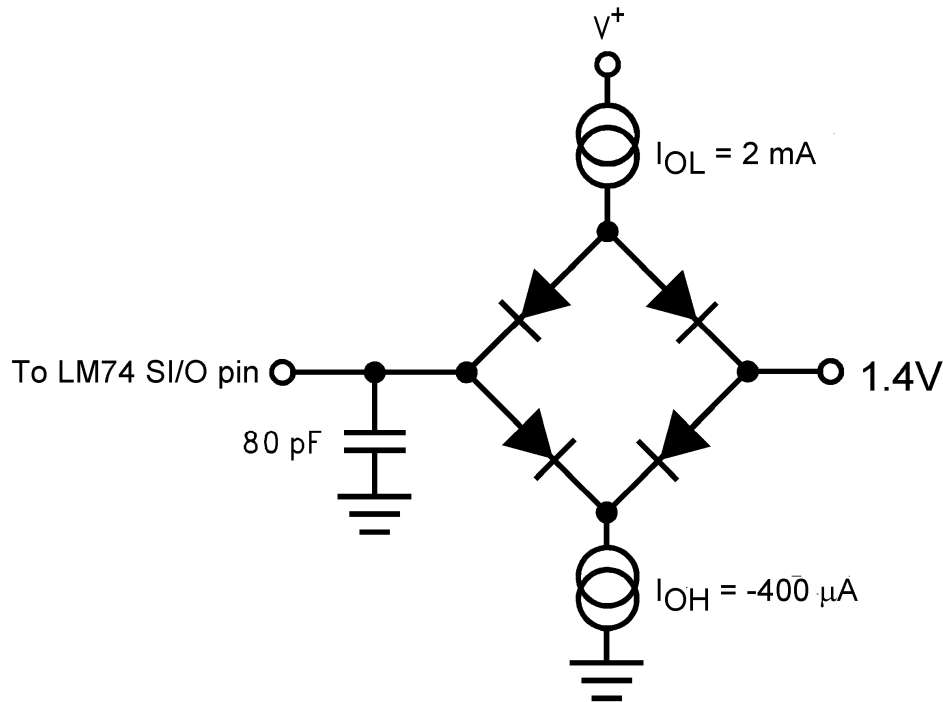

Figure 9.

Typical Performance Characteristics

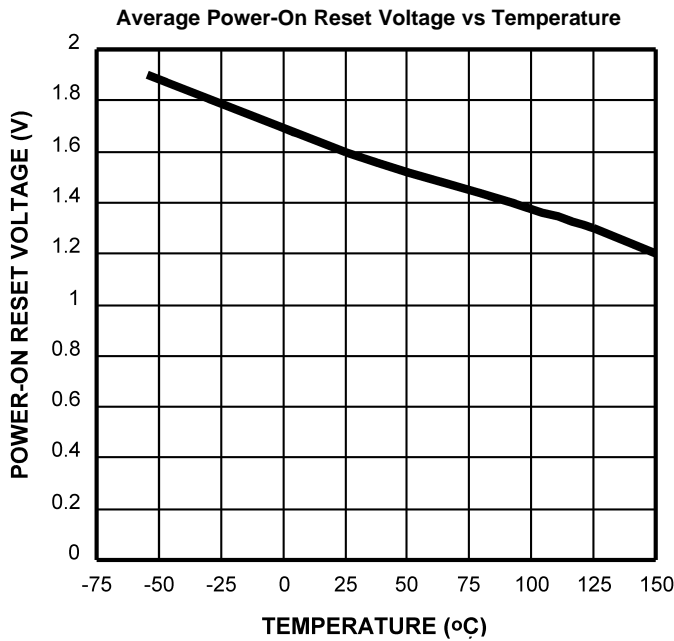

Figure 10.

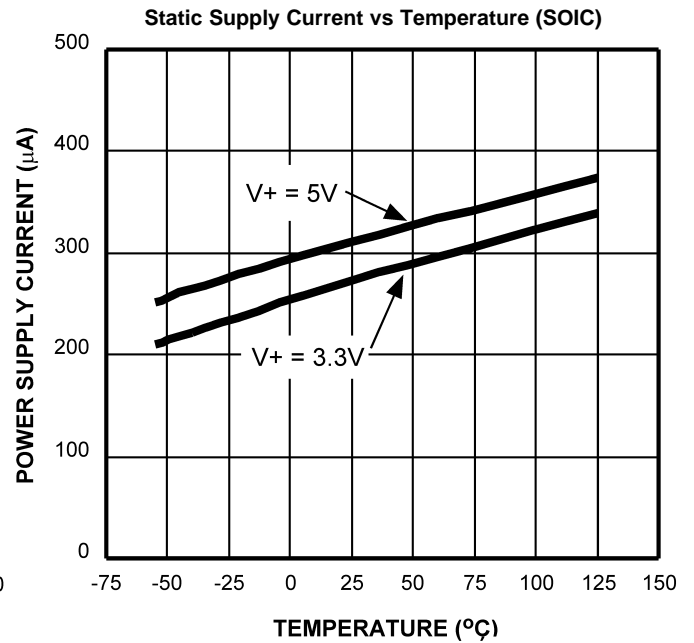

Figure 11.

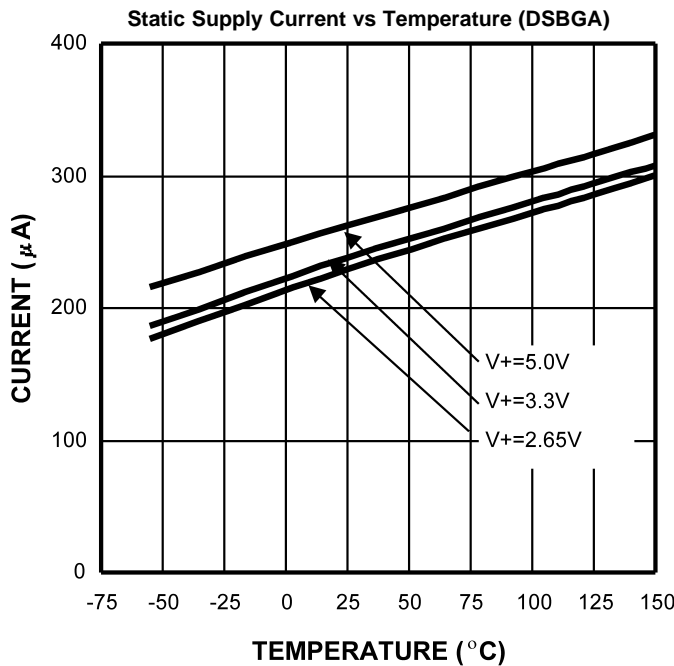

Figure 12.

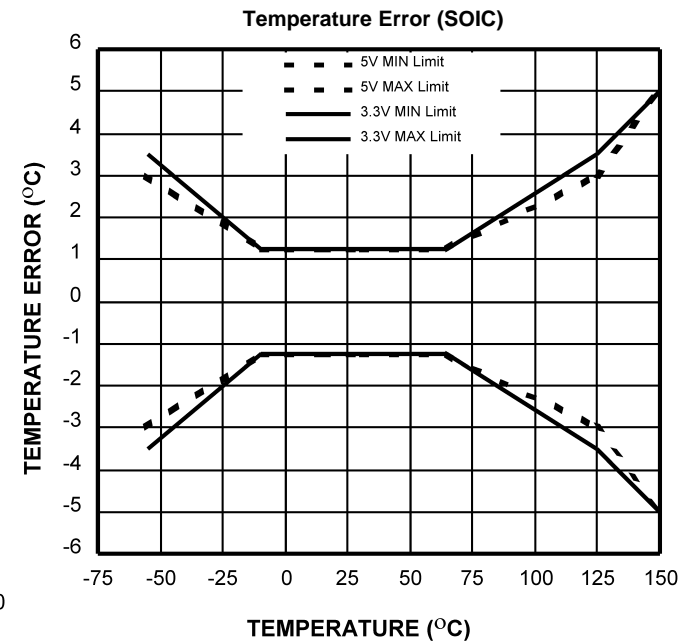

Figure 13.

FUNCTIONAL DESCRIPTION

The LM74 temperature sensor incorporates a band-gap type temperature sensor and 12-bit plus sign $\Delta\Sigma$ ADC (Delta-Sigma Analog-to-Digital Converter). Compatibility of the LM74's three wire serial interface with SPI and MICROWIRE allows simple communications with common microcontrollers and processors. Shutdown mode can be used to optimize current drain for different applications. A Manufacture's/Device ID register identifies the LM74 as Texas Instruments product.

Power Up and Power Down

When the supply voltage is less than about 1.6V (typical), the LM74 is considered powered down. The LM74 always powers up in a known state. When the supply voltage rises above 1.6V (typical), an internal Power-On Reset (POR) occurs and the temperature register will then contain a value of 1111 1111 0000 00XX, where XX indicates undefined values. See [Temperature Register \(after power-up, before first complete temperature conversion\)](#) diagram for contents after POR but before completion of the first temperature conversion.

The LM74 power-up default condition is continuous conversion mode. After completion of the first full temperature conversion, the register will contain temperature measurement data in bits D15 (the temperature data MSB) through D3 (the temperature data LSB). Bit D2 will be fixed high; bits D1 and D0 are undefined. See Section 1.5.3 for a diagram of the Temperature Register contents after the first complete temperature conversion. Note that bit D2 represents a complete conversion flag. During POR it is low and, after the first temperature conversion is complete, it goes high. This bit can be polled to indicate when the POR data in the Temperature Register has been replaced with valid temperature data.

After the first conversion, and any subsequent conversions, the value in the temperature register does not change until the completion of the next conversion, at which time the temperature register is updated with the latest temperature value.

Serial Bus Interface

The LM74 operates as a slave and is compatible with SPI or MICROWIRE bus specifications. Data is clocked out on the falling edge of the serial clock (SC), while data is clocked in on the rising edge of SC. A complete transmit/receive communication will consist of 32 serial clocks. The first 16 clocks comprise the transmit phase of communication, while the second 16 clocks are the receive phase.

When \overline{CS} is high SI/O will be in TRI-STATE. Communication should be initiated by taking chip select (\overline{CS}) low. This should not be done when SC is changing from a low to high state. Once \overline{CS} is low the serial I/O pin (SI/O) will transmit the first bit of data. The master can then read this bit with the rising edge of SC. The remainder of the data will be clocked out by the falling edge of SC. Once the 14 bits of data (one sign bit, twelve temperature bits and 1 high bit) are transmitted the SI/O line will go into TRI-STATE. \overline{CS} can be taken high at any time during the transmit phase. If \overline{CS} is brought low in the middle of a conversion the LM74 will complete the conversion and the output shift register will be updated after \overline{CS} is brought back high.

The receive phase of a communication starts after 16 SC periods. \overline{CS} can remain low for 32 SC cycles. The LM74 will read the data available on the SI/O line on the rising edge of the serial clock. Input data is to an 8-bit shift register. The part will detect the last eight bits shifted into the register. The receive phase can last up to 16 SC periods. All ones must be shifted in order to place the part into shutdown. A zero in any location will take the LM74 out of shutdown. The following codes should only be transmitted to the LM74:

- 00 hex
- 01 hex
- 03 hex
- 07 hex
- 0F hex
- 1F hex
- 3F hex
- 7F hex
- FF hex

any others may place the part into a Test Mode. Test Modes are used by Texas Instruments to thoroughly test the function of the LM74 during production testing. Only eight bits have been defined above since only the last eight transmitted are detected by the LM74, before \overline{CS} is taken HIGH.

The following communication can be used to determine the Manufacturer's/Device ID and then immediately place the part into continuous conversion mode. With \overline{CS} continuously low:

- Read 16 bits of temperature data
- Write 16 bits of data commanding shutdown
- Read 16 bits of Manufacturer's/Device ID data
- Write 8 to 16 bits of data commanding Conversion Mode
- Take \overline{CS} HIGH.

Note that one complete temperature conversion period will have to pass before the LM74 Temperature register will contain the new temperature data. Until then, it will contain a "stale" temperature (the data that was in the register before going into shutdown mode).

Temperature Data Format

Temperature data is represented by a 13-bit, two's complement word with an LSB (Least Significant Bit) equal to 0.0625°C:

Temperature	Digital Output	
	Binary	Hex
+150°C	0100 1011 0000 0111	4B 07h
+125°C	0011 1110 1000 0111	3E 87h
+25°C	0000 1100 1000 0111	0C 87h
+0.0625°C	0000 0000 0000 1111	00 0Fh
0°C	0000 0000 0000 0111	00 07h
-0.0625°C	1111 1111 1111 1111	FF FFh
-25°C	1111 0011 1000 0111	F3 87h
-55°C	1110 0100 1000 0111	E4 87h

Note: The last two bits are TRI-STATE and depicted as one in the table.

The first data byte is the most significant byte with most significant bit first, permitting only as much data as necessary to be read to determine temperature condition. For instance, if the first four bits of the temperature data indicate an overtemperature condition, the host processor could immediately take action to remedy the excessive temperatures.

Shutdown Mode/Manufacturer's ID

Shutdown mode is enabled by writing XX FF to the LM74 as shown in [Figure 16c](#). The serial bus is still active when the LM74 is in shutdown. Current draw drops to less than 10 μ A between serial communications. When in shutdown mode the LM74 always will output 1000 0000 0000 00XX. This is the manufacturer's/Device ID information. The first 5-bits of the field (1000 0XXX) are reserved for manufacturer's ID. As mentioned in Section 1.2, writing a zero to the LM74 configuration register will take it out of shutdown mode and place it in conversion mode. In other words, any valid code listed in Section 1.2 other than XX FF will put it in conversion mode. After leaving shutdown, but before the first temperature conversion is complete, the temperature register will contain the last measured temperature which resided in the temperature register before entering shutdown mode. After the completion of the first conversion, the temperature register will be updated with the new temperature data.

Internal Register Structure

The LM74 has three registers, the temperature register, the configuration register and the manufacturer's/device identification register. The temperature and manufacturer's/device identification registers are read only. The configuration register is write only.

Configuration Register

(Selects shutdown or continuous conversion modes):

Table 1. (Write Only):

D15	D14	D13	D12	D11	D10	D9	D8	D7	D6	D5	D4	D3	D2	D1	D0
X	X	X	X	X	X	X	X	Shutdown							

D0–D15 set to XX FF hex enables shutdown mode.

D0–D15 set to 00 00 hex sets Continuous conversion mode.

Note: setting D0-D15 to any other values may place the LM74 into a manufacturer's test mode, upon which the LM74 will stop responding as described. These test modes are to be used for Texas Instruments production testing only. See [Serial Bus Interface](#) for a complete discussion.

Temperature Register (after power-up, before first complete temperature conversion)

Table 2. (Read Only):

D15	D14	D13	D12	D11	D10	D9	D8	D7	D6	D5	D4	D3	D2	D1	D0
1	1	1	1	1	1	1	1	0	0	0	0	0	0	X	X

D0–D1: Undefined. TRI-STATE will be output on SI/O.

D2–D15: Power-on Reset (POR) values.

Temperature Register (after completion of first temperature conversion)

Table 3. (Read Only):

D15	D14	D13	D12	D11	D10	D9	D8	D7	D6	D5	D4	D3	D2	D1	D0
MSB	Bit 11	Bit 10	Bit 9	Bit 8	Bit 7	Bit 6	Bit 5	Bit 4	Bit 3	Bit 2	Bit 1	LSB	1	X	X

D0–D1: Undefined. TRI-STATE will be output on SI/O.

D2: High.

D3–D15: Temperature Data. One LSB = 0.0625°C. Two's complement format.

Manufacturer's Device ID Register

Table 4. (Read Only):

D15	D14	D13	D12	D11	D10	D9	D8	D7	D6	D5	D4	D3	D2	D1	D0
1	0	0	0	0	0	0	0	0	0	0	0	0	0	X	X

D0–D1: Undefined. TRI-STATE will be output on SI/O.

D2–D15: Manufacturer's/Device ID Data. This register is accessed whenever the LM74 is in shutdown mode.

Serial Bus Timing Diagrams

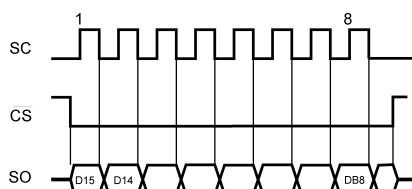

Figure 14. a) Reading Continuous Conversion - Single Eight-Bit Frame

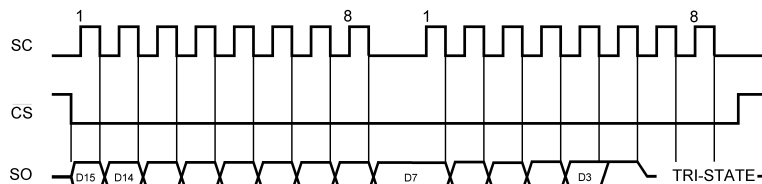

Figure 15. b) Reading Continuous Conversion - Two Eight-Bit Frames

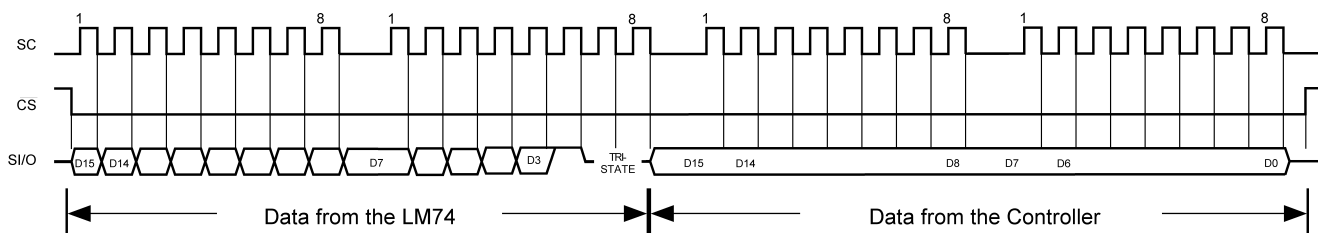

Figure 16. c) Writing Shutdown Control

Application Hints

To get the expected results when measuring temperature with an integrated circuit temperature sensor like the LM74, it is important to understand that the sensor measures its own die temperature. For the LM74, the best thermal path between the die and the outside world is through the LM74's pins. In the SOIC package all the pins on the LM74 will have an equal effect on the die temperature. Because the pins represent a good thermal path to the LM74 die, the LM74 will provide an accurate measurement of the temperature of the printed circuit board on which it is mounted. There is a less efficient thermal path between the plastic package and the LM74 die. If the ambient air temperature is significantly different from the printed circuit board temperature, it will have a small effect on the measured temperature.

In probe-type applications, the LM74 can be mounted inside a sealed-end metal tube, and can then be dipped into a bath or screwed into a threaded hole in a tank. As with any IC, the LM74 and accompanying wiring and circuits must be kept insulated and dry, to avoid leakage and corrosion. This is especially true if the circuit may operate at cold temperatures where condensation can occur. Printed-circuit coatings and varnishes such as Humiseal and epoxy paints or dips are often used to insure that moisture cannot corrode the LM74 or its connections.

DSBGA Light Sensitivity

The LM74 in the DSBGA package should not be exposed to ultraviolet light. The DSBGA package does not completely encapsulate the LM74 die in epoxy. Exposing the LM74 DSBGA package to bright sunlight will not immediately cause a change in the output reading. Our experiments show that directly exposing the circuit side (bump side) of the die to high intensity ($\geq 1\text{mW/cm}^2$) ultraviolet light, centered at a wavelength of 254nm, for greater than 20 minutes will deprogram the EEPROM cells in the LM74. Since the EEPROM is used for storing calibration coefficients, the LM74 will function but the temperature accuracy will no longer be as specified. Light can penetrate through the side of the package as well, so exposure to ultra violet radiation is not recommended even after mounting.

Typical Applications

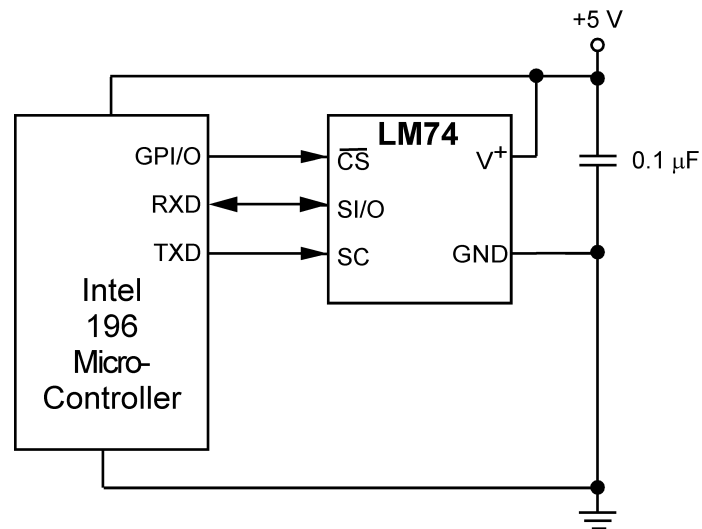

Figure 17. Temperature monitor using Intel 196 processor

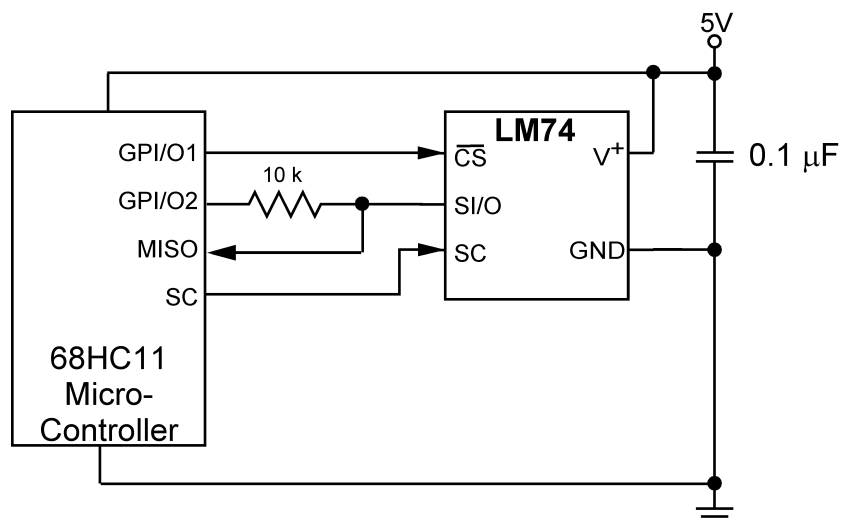

Figure 18. LM74 digital input control using microcontroller's general purpose I/O.

REVISION HISTORY

Changes from Revision J (March 2013) to Revision K	Page
• Changed layout of National Data Sheet to TI format	14

PACKAGING INFORMATION

Orderable Device	Status (1)	Package Type	Package Drawing	Pins	Package Qty	Eco Plan (2)	Lead/Ball Finish	MSL Peak Temp (3)	Op Temp (°C)	Top-Side Markings (4)	Samples
LM74CIM-3	ACTIVE	SOIC	D	8	95	TBD	Call TI	Call TI	-55 to 150	LM74 CIM3	Samples
LM74CIM-3/NOPB	ACTIVE	SOIC	D	8	95	Green (RoHS & no Sb/Br)	CU SN	Level-1-260C-UNLIM	-55 to 150	LM74 CIM3	Samples
LM74CIM-5	ACTIVE	SOIC	D	8	95	TBD	Call TI	Call TI	-55 to 150	LM74 CIM5	Samples
LM74CIM-5/NOPB	ACTIVE	SOIC	D	8	95	Green (RoHS & no Sb/Br)	CU SN	Level-1-260C-UNLIM	-55 to 150	LM74 CIM5	Samples
LM74CIMX-3	ACTIVE	SOIC	D	8	2500	TBD	Call TI	Call TI	-55 to 150	LM74 CIM3	Samples
LM74CIMX-3/NOPB	ACTIVE	SOIC	D	8	2500	Green (RoHS & no Sb/Br)	CU SN	Level-1-260C-UNLIM	-55 to 150	LM74 CIM3	Samples
LM74CIMX-5	ACTIVE	SOIC	D	8	2500	TBD	Call TI	Call TI	-55 to 150	LM74 CIM5	Samples
LM74CIMX-5/NOPB	ACTIVE	SOIC	D	8	2500	Green (RoHS & no Sb/Br)	CU SN	Level-1-260C-UNLIM	-55 to 150	LM74 CIM5	Samples
LM74CITP-3/NOPB	ACTIVE	DSBGA	YTA	5	250	Green (RoHS & no Sb/Br)	SNAGCU	Level-1-260C-UNLIM	-40 to 125	10	Samples
LM74CITPX-3/NOPB	ACTIVE	DSBGA	YTA	5	3000	Green (RoHS & no Sb/Br)	SNAGCU	Level-1-260C-UNLIM	-40 to 125	10	Samples

(1) The marketing status values are defined as follows:

ACTIVE: Product device recommended for new designs.

LIFEBUY: TI has announced that the device will be discontinued, and a lifetime-buy period is in effect.

NRND: Not recommended for new designs. Device is in production to support existing customers, but TI does not recommend using this part in a new design.

PREVIEW: Device has been announced but is not in production. Samples may or may not be available.

OBSOLETE: TI has discontinued the production of the device.

(2) Eco Plan - The planned eco-friendly classification: Pb-Free (RoHS), Pb-Free (RoHS Exempt), or Green (RoHS & no Sb/Br) - please check <http://www.ti.com/productcontent> for the latest availability information and additional product content details.

TBD: The Pb-Free/Green conversion plan has not been defined.

Pb-Free (RoHS): TI's terms "Lead-Free" or "Pb-Free" mean semiconductor products that are compatible with the current RoHS requirements for all 6 substances, including the requirement that lead not exceed 0.1% by weight in homogeneous materials. Where designed to be soldered at high temperatures, TI Pb-Free products are suitable for use in specified lead-free processes.

Pb-Free (RoHS Exempt): This component has a RoHS exemption for either 1) lead-based flip-chip solder bumps used between the die and package, or 2) lead-based die adhesive used between the die and leadframe. The component is otherwise considered Pb-Free (RoHS compatible) as defined above.

Green (RoHS & no Sb/Br): TI defines "Green" to mean Pb-Free (RoHS compatible), and free of Bromine (Br) and Antimony (Sb) based flame retardants (Br or Sb do not exceed 0.1% by weight in homogeneous material)

⁽³⁾ MSL, Peak Temp. -- The Moisture Sensitivity Level rating according to the JEDEC industry standard classifications, and peak solder temperature.

⁽⁴⁾ Only one of markings shown within the brackets will appear on the physical device.

Important Information and Disclaimer: The information provided on this page represents TI's knowledge and belief as of the date that it is provided. TI bases its knowledge and belief on information provided by third parties, and makes no representation or warranty as to the accuracy of such information. Efforts are underway to better integrate information from third parties. TI has taken and continues to take reasonable steps to provide representative and accurate information but may not have conducted destructive testing or chemical analysis on incoming materials and chemicals. TI and TI suppliers consider certain information to be proprietary, and thus CAS numbers and other limited information may not be available for release.

In no event shall TI's liability arising out of such information exceed the total purchase price of the TI part(s) at issue in this document sold by TI to Customer on an annual basis.

TAPE AND REEL INFORMATION

QUADRANT ASSIGNMENTS FOR PIN 1 ORIENTATION IN TAPE

*All dimensions are nominal

Device	Package Type	Package Drawing	Pins	SPQ	Reel Diameter (mm)	Reel Width W1 (mm)	A0 (mm)	B0 (mm)	K0 (mm)	P1 (mm)	W (mm)	Pin1 Quadrant
LM74CIMX-3	SOIC	D	8	2500	330.0	12.4	6.5	5.4	2.0	8.0	12.0	Q1
LM74CIMX-3/NOPB	SOIC	D	8	2500	330.0	12.4	6.5	5.4	2.0	8.0	12.0	Q1
LM74CIMX-5	SOIC	D	8	2500	330.0	12.4	6.5	5.4	2.0	8.0	12.0	Q1
LM74CIMX-5/NOPB	SOIC	D	8	2500	330.0	12.4	6.5	5.4	2.0	8.0	12.0	Q1
LM74CITP-3/NOPB	DSBGA	YTA	5	250	178.0	8.4	1.7	1.7	0.76	4.0	8.0	Q1
LM74CITPX-3/NOPB	DSBGA	YTA	5	3000	178.0	8.4	1.7	1.7	0.76	4.0	8.0	Q1

TAPE AND REEL BOX DIMENSIONS

*All dimensions are nominal

Device	Package Type	Package Drawing	Pins	SPQ	Length (mm)	Width (mm)	Height (mm)
LM74CIMX-3	SOIC	D	8	2500	367.0	367.0	35.0
LM74CIMX-3/NOPB	SOIC	D	8	2500	367.0	367.0	35.0
LM74CIMX-5	SOIC	D	8	2500	367.0	367.0	35.0
LM74CIMX-5/NOPB	SOIC	D	8	2500	367.0	367.0	35.0
LM74CITP-3/NOPB	DSBGA	YTA	5	250	210.0	185.0	35.0
LM74CITPX-3/NOPB	DSBGA	YTA	5	3000	210.0	185.0	35.0

YTA0005

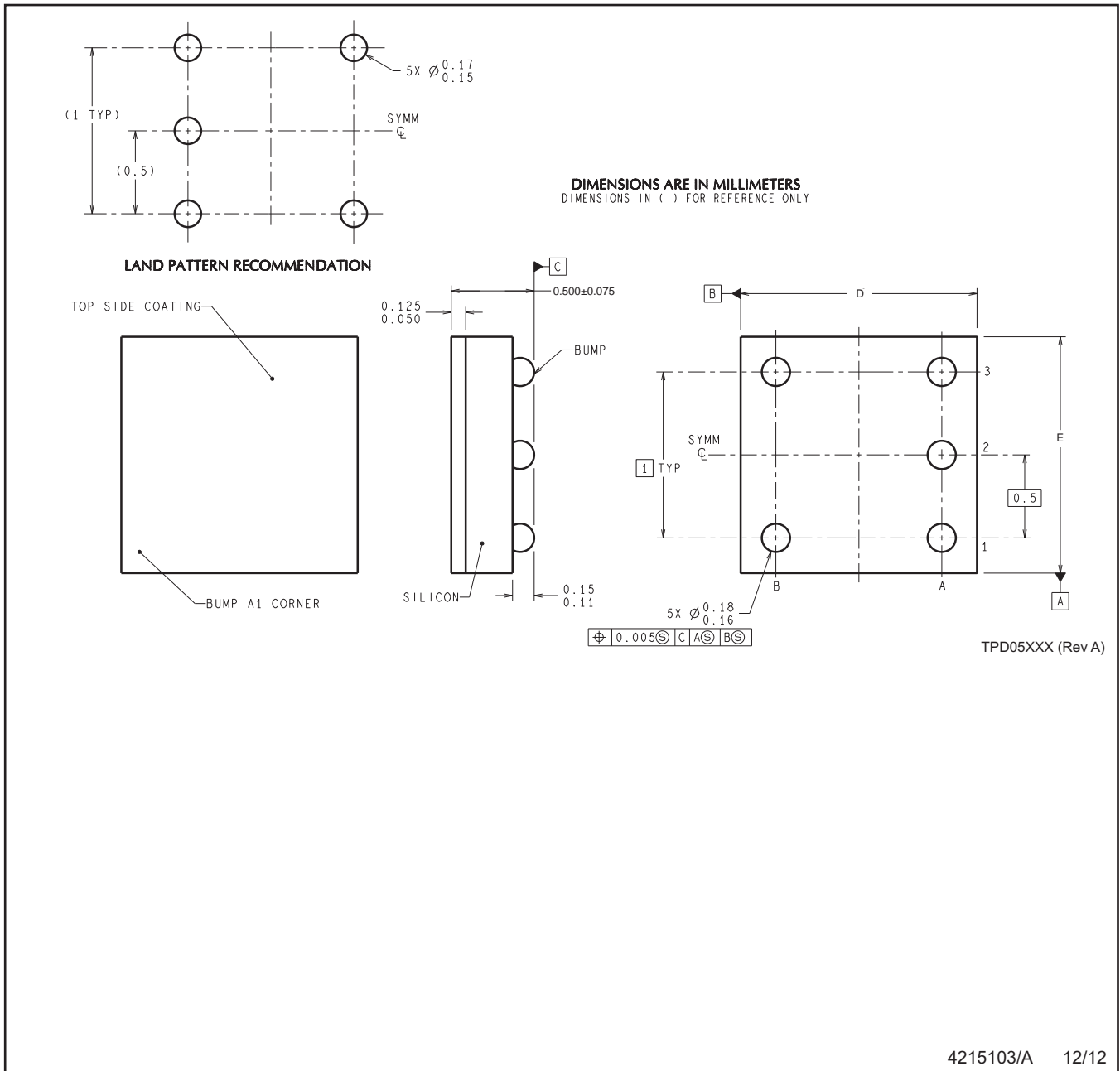

NOTES: A. All linear dimensions are in millimeters. Dimensioning and tolerancing per ASME Y14.5M-1994.
B. This drawing is subject to change without notice.

IMPORTANT NOTICE

Texas Instruments Incorporated and its subsidiaries (TI) reserve the right to make corrections, enhancements, improvements and other changes to its semiconductor products and services per JESD46, latest issue, and to discontinue any product or service per JESD48, latest issue. Buyers should obtain the latest relevant information before placing orders and should verify that such information is current and complete. All semiconductor products (also referred to herein as "components") are sold subject to TI's terms and conditions of sale supplied at the time of order acknowledgment.

TI warrants performance of its components to the specifications applicable at the time of sale, in accordance with the warranty in TI's terms and conditions of sale of semiconductor products. Testing and other quality control techniques are used to the extent TI deems necessary to support this warranty. Except where mandated by applicable law, testing of all parameters of each component is not necessarily performed.

TI assumes no liability for applications assistance or the design of Buyers' products. Buyers are responsible for their products and applications using TI components. To minimize the risks associated with Buyers' products and applications, Buyers should provide adequate design and operating safeguards.

TI does not warrant or represent that any license, either express or implied, is granted under any patent right, copyright, mask work right, or other intellectual property right relating to any combination, machine, or process in which TI components or services are used. Information published by TI regarding third-party products or services does not constitute a license to use such products or services or a warranty or endorsement thereof. Use of such information may require a license from a third party under the patents or other intellectual property of the third party, or a license from TI under the patents or other intellectual property of TI.

Reproduction of significant portions of TI information in TI data books or data sheets is permissible only if reproduction is without alteration and is accompanied by all associated warranties, conditions, limitations, and notices. TI is not responsible or liable for such altered documentation. Information of third parties may be subject to additional restrictions.

Resale of TI components or services with statements different from or beyond the parameters stated by TI for that component or service voids all express and any implied warranties for the associated TI component or service and is an unfair and deceptive business practice. TI is not responsible or liable for any such statements.

Buyer acknowledges and agrees that it is solely responsible for compliance with all legal, regulatory and safety-related requirements concerning its products, and any use of TI components in its applications, notwithstanding any applications-related information or support that may be provided by TI. Buyer represents and agrees that it has all the necessary expertise to create and implement safeguards which anticipate dangerous consequences of failures, monitor failures and their consequences, lessen the likelihood of failures that might cause harm and take appropriate remedial actions. Buyer will fully indemnify TI and its representatives against any damages arising out of the use of any TI components in safety-critical applications.

In some cases, TI components may be promoted specifically to facilitate safety-related applications. With such components, TI's goal is to help enable customers to design and create their own end-product solutions that meet applicable functional safety standards and requirements. Nonetheless, such components are subject to these terms.

No TI components are authorized for use in FDA Class III (or similar life-critical medical equipment) unless authorized officers of the parties have executed a special agreement specifically governing such use.

Only those TI components which TI has specifically designated as military grade or "enhanced plastic" are designed and intended for use in military/aerospace applications or environments. Buyer acknowledges and agrees that any military or aerospace use of TI components which have **not** been so designated is solely at the Buyer's risk, and that Buyer is solely responsible for compliance with all legal and regulatory requirements in connection with such use.

TI has specifically designated certain components as meeting ISO/TS16949 requirements, mainly for automotive use. In any case of use of non-designated products, TI will not be responsible for any failure to meet ISO/TS16949.

Products

Audio	www.ti.com/audio
Amplifiers	amplifier.ti.com
Data Converters	dataconverter.ti.com
DLP® Products	www.dlp.com
DSP	dsp.ti.com
Clocks and Timers	www.ti.com/clocks
Interface	interface.ti.com
Logic	logic.ti.com
Power Mgmt	power.ti.com
Microcontrollers	microcontroller.ti.com
RFID	www.ti-rfid.com
OMAP Applications Processors	www.ti.com/omap
Wireless Connectivity	www.ti.com/wirelessconnectivity

Applications

Automotive and Transportation	www.ti.com/automotive
Communications and Telecom	www.ti.com/communications
Computers and Peripherals	www.ti.com/computers
Consumer Electronics	www.ti.com/consumer-apps
Energy and Lighting	www.ti.com/energy
Industrial	www.ti.com/industrial
Medical	www.ti.com/medical
Security	www.ti.com/security
Space, Avionics and Defense	www.ti.com/space-avionics-defense
Video and Imaging	www.ti.com/video

TI E2E Community

e2e.ti.com